

K9 SBM XT HD 80 a catena

CS Italia s.r.l.



Optional su richiesta info@carrellispeciali.it 

K9 SBM XT HD 80 a catena

CS Italia s.r.l.

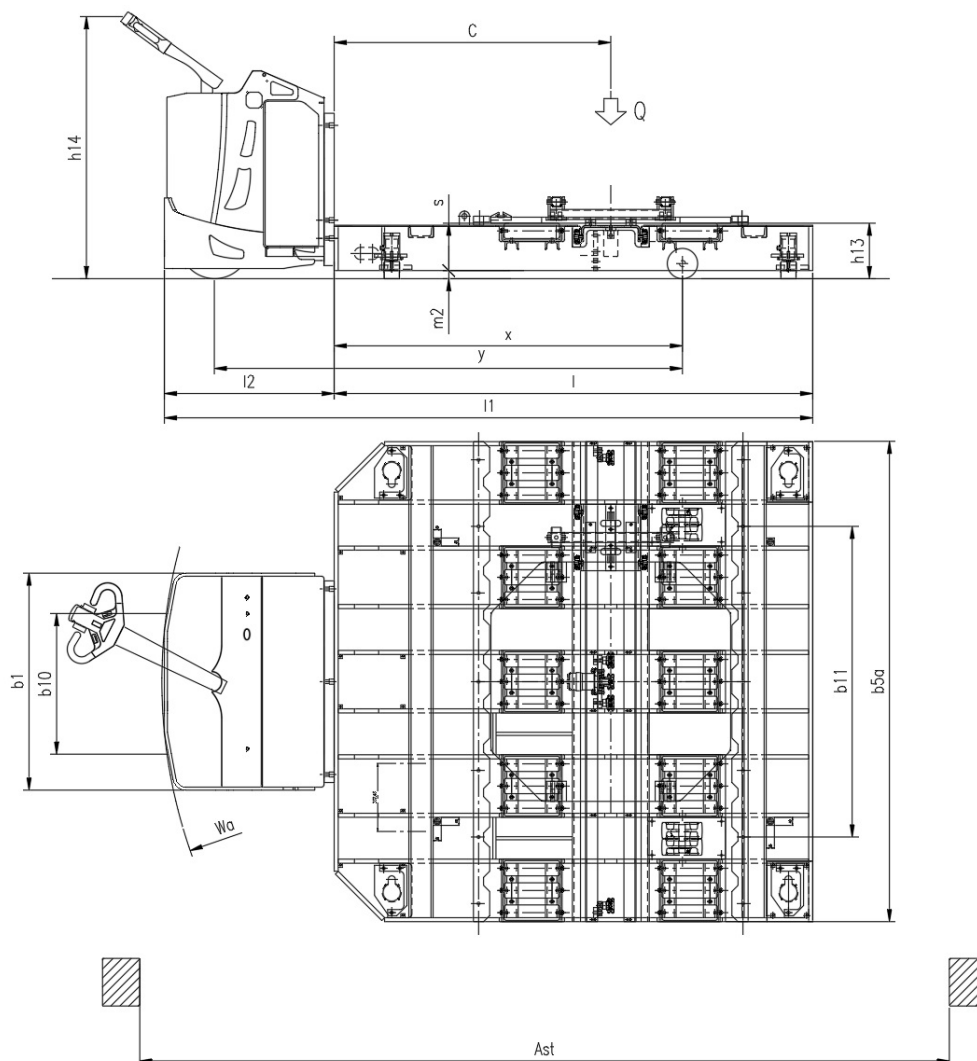

Illustrazioni e dati tecnici non sono impegnativi. Il costruttore si riserva il diritto di apportare modifiche senza preavviso.

Tipologia K9 SBM XT HD 80 a catena

Categoria Pianali

General info	1.1	Manufacturer			CSI s.r.l.
	1.2	Model			K9 SBM XT HD 80 a catena
	1.3	Drive			elettrico AC
	1.4	Operator type			a timone
	1.5	Load capacity	Q	t	8
	1.6	Load centre	c	mm	1370
	1.8	Load distance to wheel axle	x	mm	1725
	1.9	Wheelbase	y	mm	1820
	Weights				
	2.1	Truck weight without battery		Kg	3300
Wheels and chassis					
	3.1	Wheels			Poliuretano
	3.2	Wheels size front		mm	350x140
	3.3	Wheels size rear		mm	150X80
	3.4	Additional wheels size		mm	200X80
	3.5	Number of rear/front wheels (x = Traction wheel)			1x/2+2/4
	3.6	Front wheelbase	b10	mm	600
	3.7	Rear wheelbase	b11	mm	1540
Dimensions					
	4.9	Height of tiller (min/max)	h14	mm	975/1535
	4.15	Height forks lowered	h13	mm	275
	4.20	Length to face of forks	l2	mm	840
	4.21	Overall width	b1	mm	1076
	4.22	Forks dimensions	s/e/l	mm	235/2380/2370
	4.25a	Overall platform width size	b5a	mm	2380
	4.31	Ground clearance		mm	40
	4.32	Distanza da piano di lavoro a inizio forca	m2	mm	40
	4.34	Aisle width	ast	mm	3920
	4.35	Turning radius	wa	mm	2570
Performance					
	5.1	Travel speed with/without load		Km/h	3/5
	5.8	Maximum gradeability with/without load		%	1/3
	5.10	Service brake			elettrico
Motor					
	6.1	Traction motor S2 60 min.		Kw	5
	6.3	Battery			no
	6.4	Battery - voltage and nominal capacity		V/Ah	48v 250ah
	6.5	Battery weight		Kg	420
	Dim. batteria	Battery size		mm	1015/255/627
Other					
	8.1	Traction control			proporzionale
	8.4	Noise level driver place			<70