

K9 SOB DT HD 100

CS Italia s.r.l.



Optional su richiesta info@carrellispeciali.it ✉

K9 SOB DT HD 100

CS Italia s.r.l.

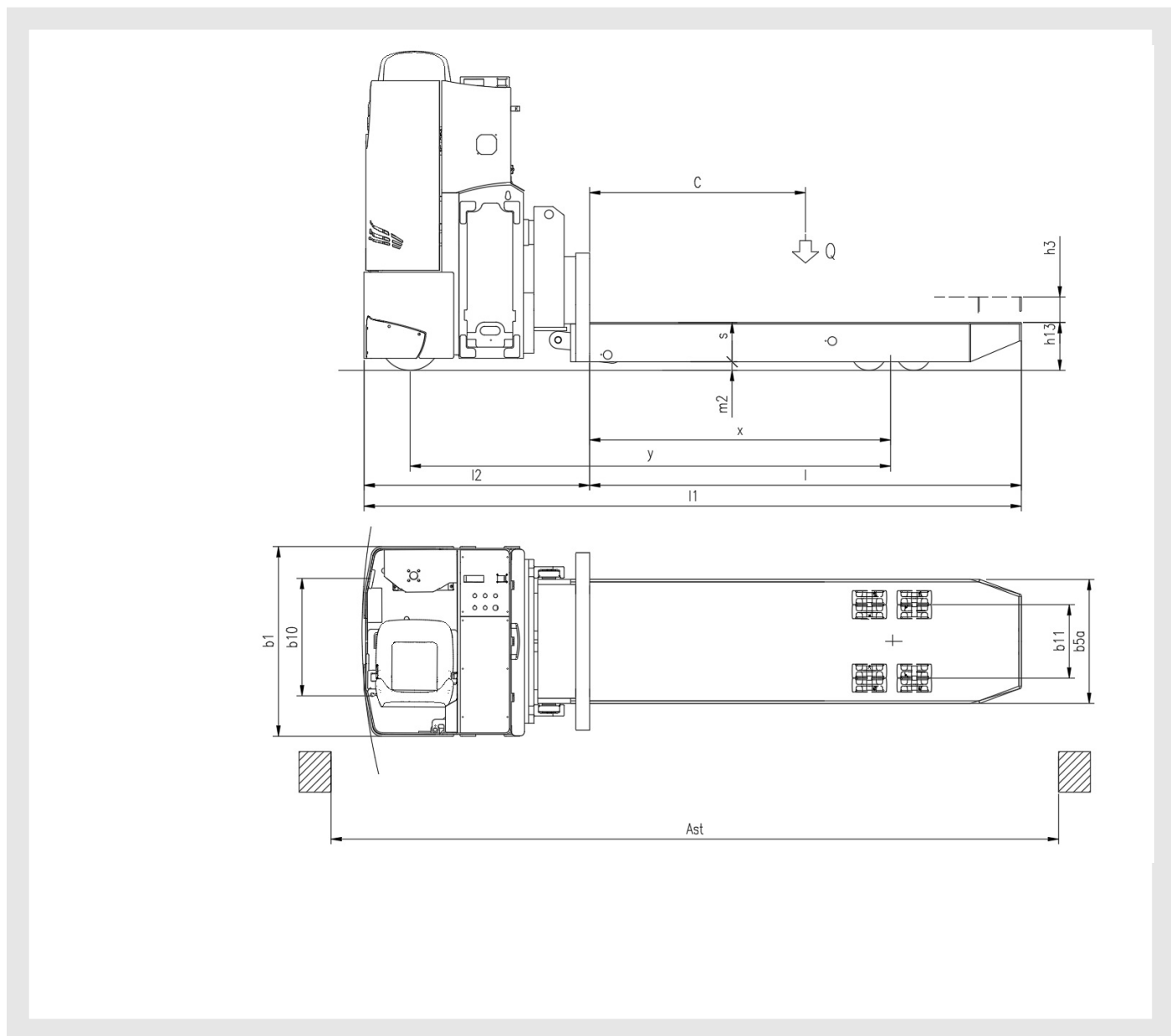

Illustrazioni e dati tecnici non sono impegnativi. Il costruttore si riserva il diritto di apportare modifiche senza preavviso.

Tipologia K9 SOB DT HD 100

Categoria Pianali

General info	1.1	Manufacturer			CSI s.r.l.
	1.2	Model			K9 SOB DT HD 100
	1.3	Drive			elettrico AC
	1.4	Operator type			a volante
	1.5	Load capacity	Q	t	10
	1.6	Load centre	c	mm	1250
	1.8	Load distance to wheel axle	x	mm	1740
	1.9	Wheelbase	y	mm	2800
	Weights				
	2.1	Truck weight without battery		Kg	3100
Wheels and chassis					
	3.1	Wheels			Poliuretano
	3.2	Wheels size front		mm	350x140
	3.3	Wheels size rear		mm	200X80
	3.5	Number of rear/front wheels (x = Traction wheel)			2x/4+4
	3.6	Front wheelbase	b10	mm	600
	3.7	Rear wheelbase	b11	mm	430
Dimensions					
	4.4	Lift height	h3	mm	115
	4.15	Height forks lowered	h13	mm	280
	4.19	Overall length	l1	mm	3800
	4.20	Length to face of forks	l2	mm	1300
	4.21	Overall width	b1	mm	1076
	4.22	Forks dimensions	s/e/l	mm	260/720/2500
	4.25a	Overall platform width size	b5a	mm	720
	4.31	Ground clearance		mm	50
	4.32	Distanza da piano di lavoro a inizio forca	m2	mm	50
	4.34	Aisle width	ast	mm	4210
	4.35	Turning radius	wa	mm	3580
Performance					
	5.1	Travel speed with/without load		Km/h	3/6
	5.2	Lifting speed with/without load		m/s	0.11/0.33
	5.3	Lowering speed with/without load		m/s	0.5/0.2
	5.8	Maximum gradeability with/without load		%	1/3
	5.10	Service brake			elettrico
Motor					
	6.1	Traction motor S2 60 min.		Kw	5
	6.3	Battery			Piombo acido
	6.4	Battery - voltage and nominal capacity		V/Ah	48V250Ah
	6.5	Battery weight		Kg	420
	Dim. batteria	Battery size		mm	1015/255/627
Other					
	8.1	Traction control			AC
	8.4	Noise level driver place			<70