

**K9 OB XT 40**

CS Italia s.r.l.



Optional su richiesta [info@carrellispeciali.it](mailto:info@carrellispeciali.it) 

# K9 OB XT 40

CS Italia s.r.l.

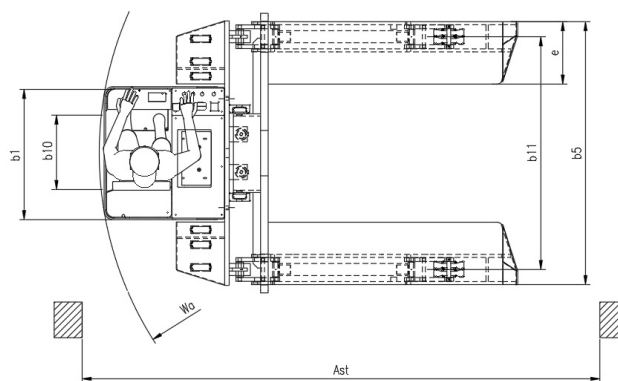
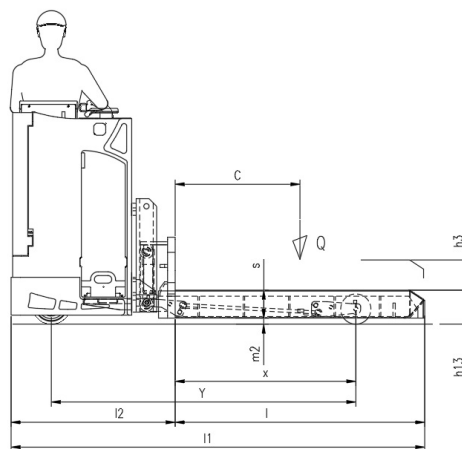
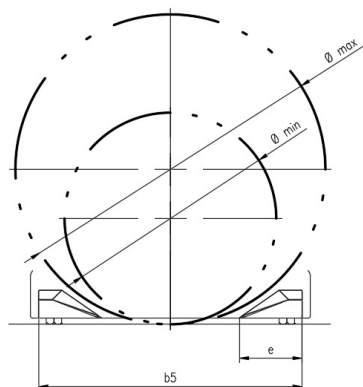

Illustrazioni e dati tecnici non sono impegnativi. Il costruttore si riserva il diritto di apportare modifiche senza preavviso.

**Tipologia** K9 OB XT 40

**Categoria** Portabobine

<b>General info</b>	1.1	Manufacturer			CSI s.r.l.
	1.2	Model			K9 OB XT 40
	1.3	Drive			elettrico AC
	1.4	Operator type			a volante
	1.5	Load capacity	Q	t	4
	1.6	Load centre	c	mm	825
	1.8	Load distance to wheel axle	x	mm	1200
	1.9	Wheelbase	y	mm	2020
	<b>Weights</b>				
	2.1	Truck weight without battery		Kg	1600
<b>Wheels and chassis</b>					
	3.1	Wheels			Poliuretano
	3.2	Wheels size front		mm	254x100
	3.3	Wheels size rear		mm	200X50
	3.4	Additional wheels size		mm	150x50
	3.5	Number of rear/front wheels (x = Traction wheel)			1x+2/2+2
	3.6	Front wheelbase	b10	mm	500
	3.7	Rear wheelbase	b11	mm	1540
<b>Dimensions</b>					
	4.4	Lift height	h3	mm	200
	4.13	Minimum diameter	Ø min	mm	1400
	4.14	Maximum diameter	Ø max	mm	2050
	4.15	Height forks lowered	h13	mm	230
	4.19	Overall length	l1	mm	2735
	4.20	Length to face of forks	l2	mm	1085
	4.21	Overall width	b1	mm	880
	4.22	Forks dimensions	s/e/l	mm	40/185/1650
	4.31	Ground clearance		mm	50
	4.32	Distanza da piano di lavoro a inizio forca	m2	mm	30
	4.35	Turning radius	wa	mm	2315
<b>Performance</b>					
	5.1	Travel speed with/without load		Km/h	3/6
	5.2	Lifting speed with/without load		m/s	0.11/0.33
	5.3	Lowering speed with/without load		m/s	0.5/0.2
	5.8	Maximum gradeability with/without load		%	1/3
	5.10	Service brake			elettrico
<b>Motor</b>					
	6.1	Traction motor S2 60 min.		Kw	2.5
	6.2	Lift motor S3		Kw	2.2
	6.3	Battery			Piombo acido
	6.4	Battery - voltage and nominal capacity		V/Ah	24V / 240Ah
	6.5	Battery weight		Kg	210
	Dim. batteria	Battery size		mm	800/280/800
<b>Other</b>					
	8.1	Traction control			proporzionale
	8.4	Noise level driver place			<70