

K9 SBM XT HD 200

CS Italia s.r.l.



Optional su richiesta info@carrellispeciali.it ✉

K9 SBM XT HD 200

CS Italia s.r.l.

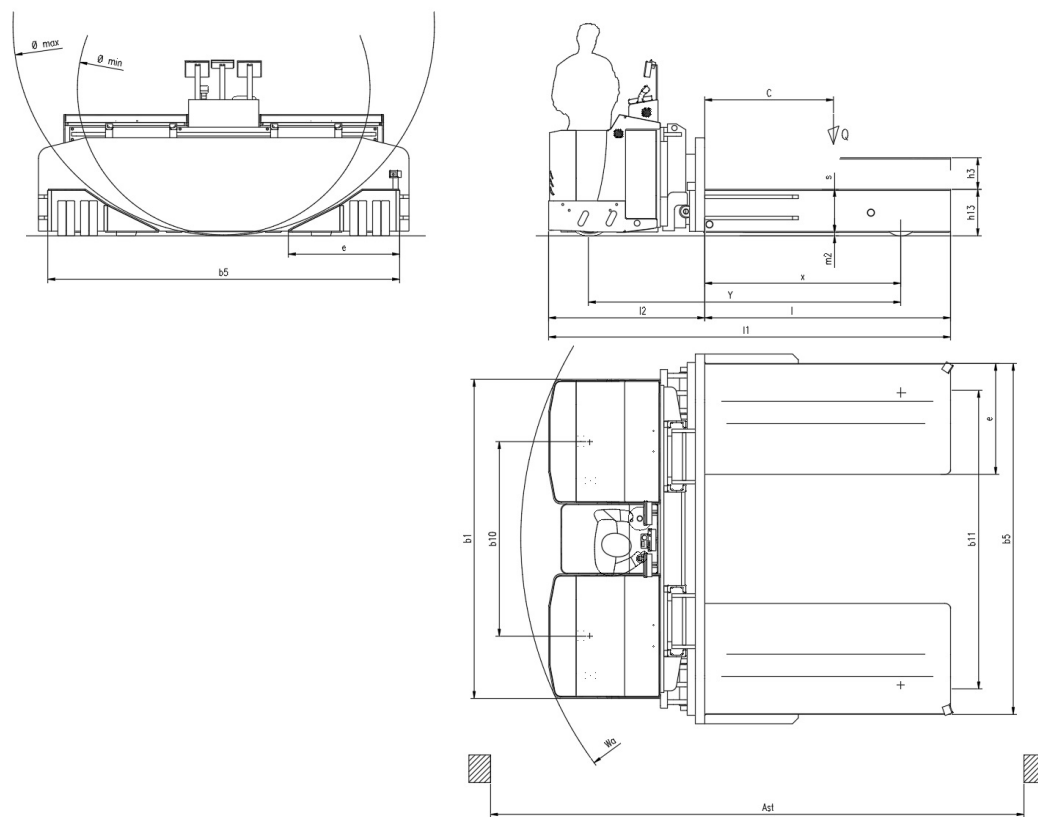

Illustrazioni e dati tecnici non sono impegnativi. Il costruttore si riserva il diritto di apportare modifiche senza preavviso.

Tipologia K9 SBM XT HD 200

Categoria Portabobine

General info	1.1	Manufacturer			CSI s.r.l.
	1.2	Model			K9 SBM XT HD 200
	1.3	Drive			elettrico AC
	1.4	Operator type			a volante
	1.5	Load capacity	Q	t	20
	1.6	Load centre	c	mm	1000
	1.8	Load distance to wheel axle	x	mm	1680
	1.9	Wheelbase	y	mm	2680
	Weights				
	2.1	Truck weight without battery		Kg	8000
Wheels and chassis					
	3.1	Wheels			Poliuretano
	3.2	Wheels size front		mm	406x170
	3.3	Wheels size rear		mm	300x70
	3.5	Number of rear/front wheels (x = Traction wheel)			2x/4+4
	3.6	Front wheelbase	b10	mm	1670
	3.7	Rear wheelbase	b11	mm	2560
Dimensions					
	4.4	Lift height	h3	mm	200
	4.13	Minimum diameter	Ø min	mm	2500
	4.14	Maximum diameter	Ø max	mm	3600
	4.15	Height forks lowered	h13	mm	285
	4.19	Overall length	l1	mm	3435
	4.20	Length to face of forks	l2	mm	1335
	4.21	Overall width	b1	mm	2740
	4.22	Forks dimensions	s/e/l	mm	370/950/2100
	4.25	Overall forks width size	b5	mm	3010
	4.31	Ground clearance		mm	50
	4.32	Distanza da piano di lavoro a inizio forca	m2	mm	15
	4.34	Aisle width	ast	mm	3250
	4.35	Turning radius	wa	mm	4560
Performance					
	5.1	Travel speed with/without load		Km/h	2/5
	5.2	Lifting speed with/without load		m/s	0.11/0.33
	5.3	Lowering speed with/without load		m/s	0.5/0.2
	5.8	Maximum gradeability with/without load		%	1/3
	5.10	Service brake			elettrico
Motor					
	6.1	Traction motor S2 60 min.		Kw	5
	6.2	Lift motor S3		Kw	2.2
	6.3	Battery			no
	6.4	Battery - voltage and nominal capacity		V/Ah	n° 48V250Ah
	6.5	Battery weight		Kg	420
	Dim. batteria	Battery size		mm	1015/255/627
Other					
	8.1	Traction control			proporzionale
	8.4	Noise level driver place			<70