

4 VR 4516

CS Italia s.r.l.



Optional su richiesta info@carrellispeciali.it 

4 VR 4516

CS Italia s.r.l.

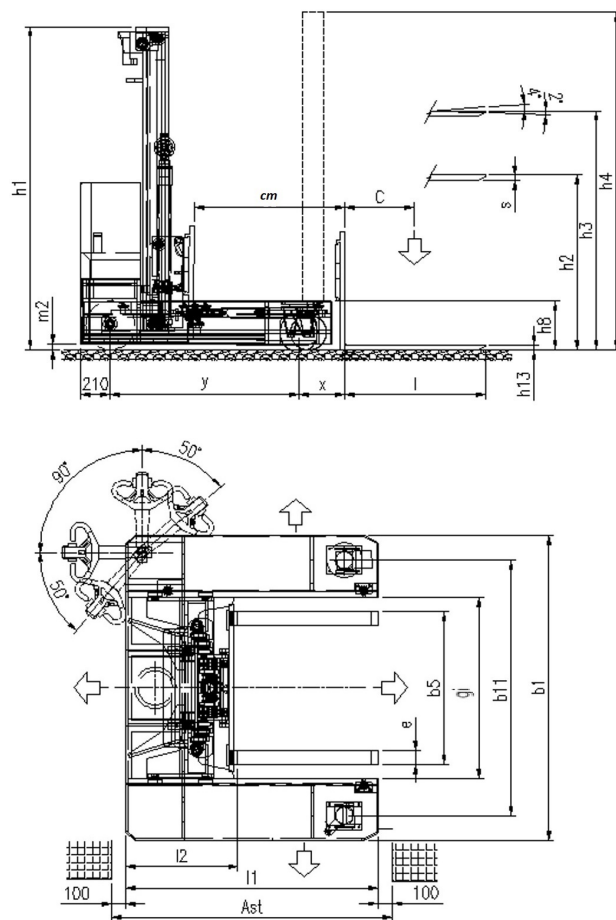

Illustrazioni e dati tecnici non sono impegnativi. Il costruttore si riserva il diritto di apportare modifiche senza preavviso.

Tipologia 4 VR 4516

Categoria

General info	1.1	Manufacturer			CSI s.r.l.
	1.2	Model			4 VR 4516
	1.3	Drive			elettrico AC
	1.4	Operator type			a timone
	1.5	Load capacity	Q	t	1.6
	1.6	Load centre	c	mm	400/500/600
	1.8	Load distance to wheel axle	x	mm	340
	1.9	Wheelbase	y	mm	1180-1380-1580
	Weights				
2.1	Truck weight without battery			Kg	4000
Wheels and chassis					
3.1	Wheels				Poliuretano
3.2	Wheels size front			mm	350x140
3.3	Wheels size rear			mm	250x50
3.5	Number of rear/front wheels (x = Traction wheel)				1x/4
3.7	Rear wheelbase	b11		mm	1835
3.10	Inside width legs	gi		mm	1300
3.11	Legs height	h8		mm	350
Dimensions					
4.1	Tilt			°	-1/+2
4.2	Height mast lowered	h1		mm	2320
4.3	Free lift	h2		mm	1500
4.4	Lift height	h3		mm	4500
4.5	Height mast extended	h4		mm	5320
4.10	Mast raise	cm		mm	900-1100-1300
4.15	Height forks lowered	h13		mm	45
4.19	Overall length	l1		mm	1700-1900-2100
4.20	Length to face of forks	l2		mm	900
4.21	Overall width	b1		mm	2180
4.22	Forks dimensions	s/e/l		mm	40/100/(800-1000-1200)
4.23	Carriage forks				FEM 2A
4.31	Ground clearance			mm	40
4.34	Aisle width	ast		mm	1900-2100-2300
4.35	Turning radius	wa		mm	2770
Performance					
5.1	Travel speed with/without load			Km/h	3/5
5.2	Lifting speed with/without load			m/s	0,11/0,33
5.3	Lowering speed with/without load			m/s	0,5/0,2
5.8	Maximum gradeability with/without load			%	1/3
5.10	Service brake				elettrico
Motor					
6.1	Traction motor S2 60 min.			Kw	5
6.2	Lift motor S3			Kw	4
6.3	Battery				Piombo acido
6.4	Battery - voltage and nominal capacity			V/Ah	48V/350Ah
6.5	Battery weight			Kg	270
Dim. batteria	Battery size			mm	495/495/695
Other					
8.1	Traction control				elettronico
8.4	Noise level driver place				<70