

SBC XTS 3015

CS Italia s.r.l.



Optional su richiesta info@carrellispeciali.it ✉

SBC XTS 3015

CS Italia s.r.l.

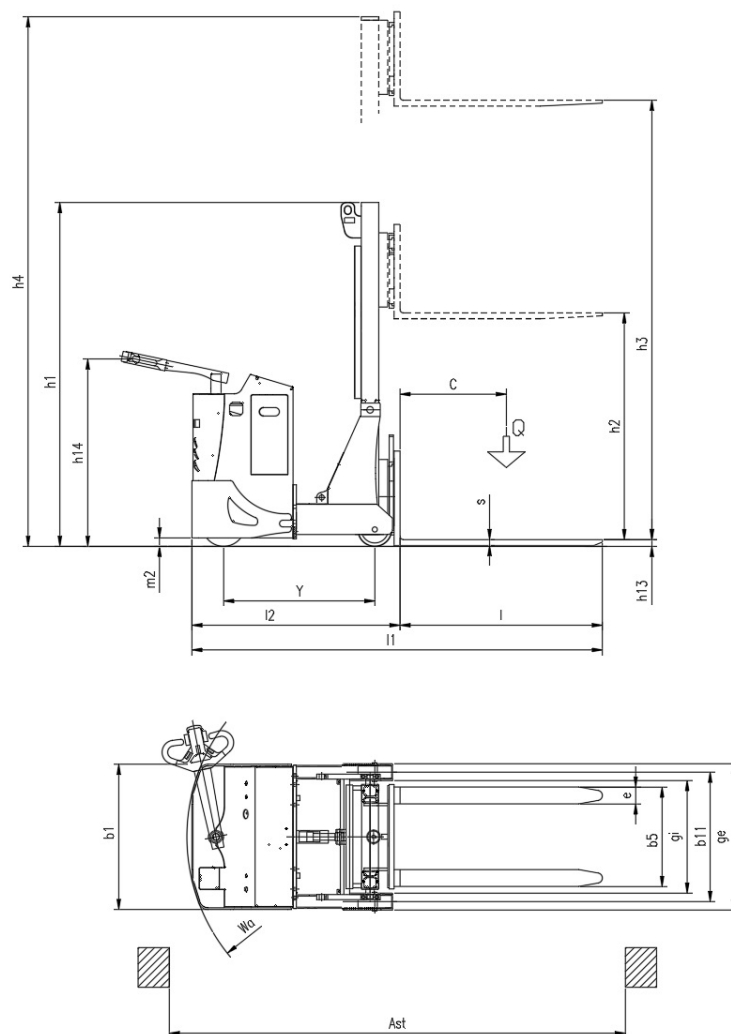

Illustrazioni e dati tecnici non sono impegnativi. Il costruttore si riserva il diritto di apportare modifiche senza preavviso.

Tipologia SBC XTS 3015

Categoria Contrappesati

General info	1.1	Manufacturer			CSI s.r.l.
	1.2	Model			SBC XTS 3010
	1.3	Drive			elettrico AC
	1.4	Operator type			a timone
	1.5	Load capacity	Q	t	1
	1.6	Load centre	c	mm	600
	1.9	Wheelbase	y	mm	900
Weights	2.1	Truck weight without battery		Kg	1800
Wheels and chassis	3.1	Wheels			Poliuretano
	3.2	Wheels size front		mm	254x100
	3.3	Wheels size rear		mm	200x80
	3.5	Number of rear/front wheels (x = Traction wheel)			1x/2
	3.7	Rear wheelbase	b11	mm	770
	3.9	Overall width legs	ge	mm	868
	3.10	Inside width legs	gi	mm	686
Dimensions	4.1	Tilt		°	-1/+2
	4.2	Height mast lowered	h1	mm	2020
	4.3	Free lift	h2	mm	1500
	4.4	Lift height	h3	mm	2960
	4.5	Height mast extended	h4	mm	3550
	4.9	Height of tiller (min/max)	h14	mm	975/1535
	4.15	Height forks lowered	h13	mm	40
	4.19	Overall length	l1	mm	2430
	4.20	Length to face of forks	l2	mm	1230
	4.21	Overall width	b1	mm	862
	4.22	Forks dimensions	s/e/l	mm	35/100/1200
	4.23	Carriage forks			FEM 2A
	4.25	Overall forks width size	b5	mm	200-620
	4.31	Ground clearance		mm	40
	4.34	Aisle width	ast	mm	2700
4.35	Turning radius	wa	mm	1115	
Performance	5.1	Travel speed with/without load		Km/h	2/4
	5.2	Lifting speed with/without load		m/s	0,11/0,33
	5.3	Lowering speed with/without load		m/s	0,5/0,2
	5.8	Maximum gradeability with/without load		%	1/2
	5.10	Service brake			elettrico
Motor	6.1	Traction motor S2 60 min.		Kw	2.5
	6.2	Lift motor S3		Kw	3
	6.3	Battery			Piombo acido
	6.4	Battery - voltage and nominal capacity		V/Ah	24V/240 Ah
	6.5	Battery weight		Kg	210
	Dim. batteria	Battery size		mm	810x210x450
Other	8.1	Traction control			proporzionale