

**SBC OB X HD 3025**

CS Italia s.r.l.



Optional su richiesta [info@carrellispeciali.it](mailto:info@carrellispeciali.it) 

# SBC OB X HD 3025

CS Italia s.r.l.

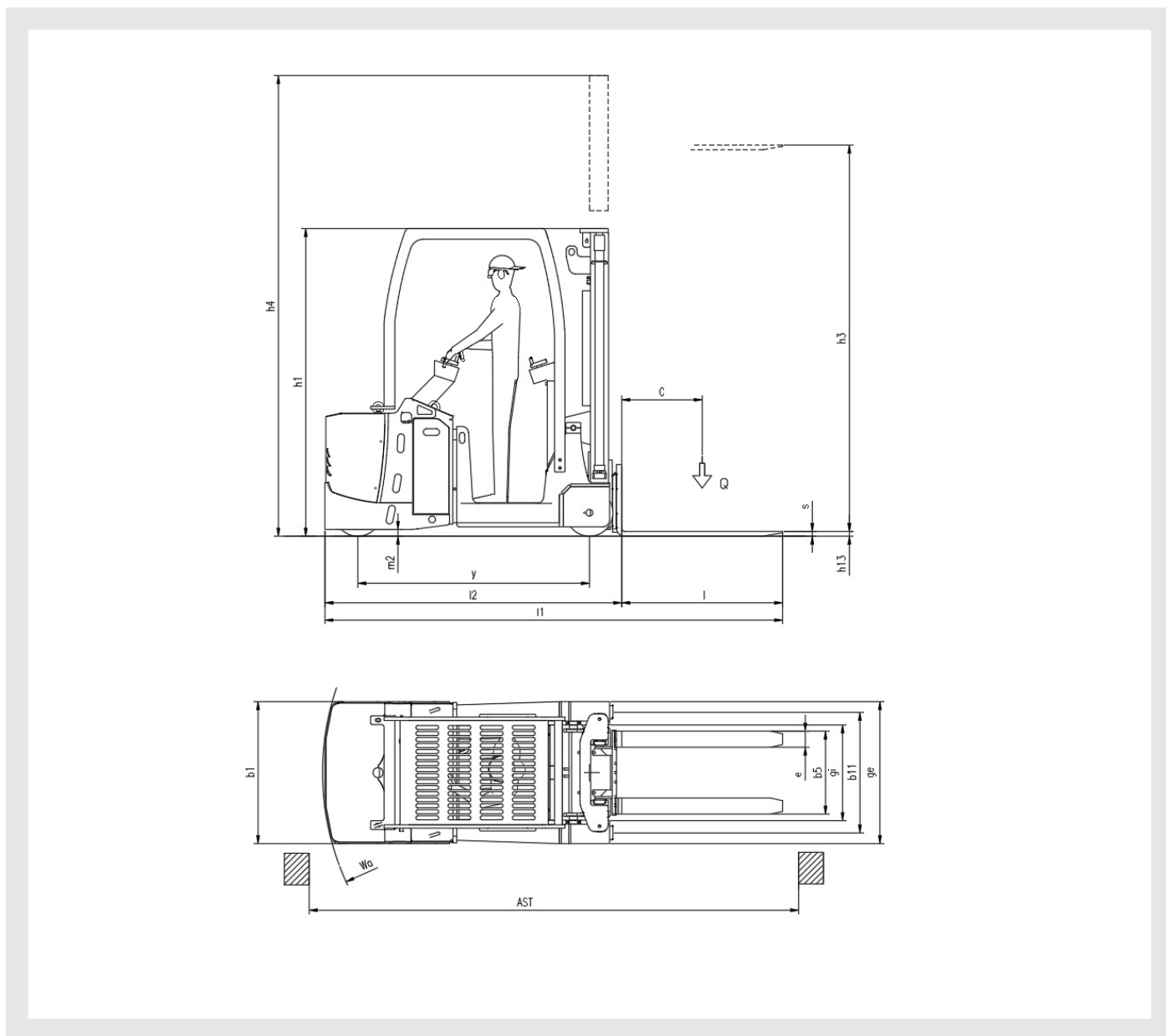

Illustrazioni e dati tecnici non sono impegnativi. Il costruttore si riserva il diritto di apportare modifiche senza preavviso.

**Tipologia** SBC OB X HD 3025

**Categoria** Contrappesati

<b>General info</b>	1.1	Manufacturer			CSI s.r.l.
	1.2	Model			SBC OB X HD 3025
	1.3	Drive			elettrico AC
	1.4	Operator type			a volante
	1.5	Load capacity	Q	t	2.5
	1.9	Wheelbase	y	mm	1728
<b>Weights</b>	2.1	Truck weight without battery		Kg	3700
<b>Wheels and chassis</b>	3.1	Wheels			Poliuretano
	3.2	Wheels size front		mm	350x140
	3.3	Wheels size rear		mm	350x100
	3.5	Number of rear/front wheels (x = Traction wheel)			1x/2
	3.7	Rear wheelbase	b11	mm	900
	3.9	Overall width legs	ge	mm	1062
	3.10	Inside width legs	gi	mm	712
	<b>Dimensions</b>	4.1	Tilt		°
4.2		Height mast lowered	h1	mm	2140
4.4		Lift height	h3	mm	2960
4.5		Height mast extended	h4	mm	3720
4.15		Height forks lowered	h13	mm	50
4.19		Overall length	l1	mm	3415
4.20		Length to face of forks	l2	mm	2215
4.21		Overall width	b1	mm	1062
4.22		Forks dimensions	s/e/l	mm	50/120/1200
4.23		Carriage forks			FEM 2A
4.25		Overall forks width size	b5	mm	240-620
4.31		Ground clearance		mm	40
4.32		Distanza da piano di lavoro a inizio forca	m2	mm	40
4.34		Aisle width	ast	mm	3720
4.35		Turning radius	wa	mm	1992
<b>Performance</b>		5.1	Travel speed with/without load		Km/h
	5.2	Lifting speed with/without load		m/s	0,11/0,33
	5.3	Lowering speed with/without load		m/s	0,5/0,2
	5.8	Maximum gradeability with/without load		%	2/3
	5.10	Service brake			elettrico
<b>Motor</b>	6.1	Traction motor S2 60 min.		Kw	3
	6.2	Lift motor S3		Kw	3
	6.3	Battery			Piombo acido
	6.4	Battery - voltage and nominal capacity		V/Ah	24V /420Ah
	6.5	Battery weight		Kg	320
	Dim. batteria	Battery size		mm	1015/255/570h
<b>Other</b>	8.1	Traction control			proporzionale
	8.4	Noise level driver place			<70