

**SBC XT HD 5025**

CS Italia s.r.l.



Optional su richiesta [info@carrellispeciali.it](mailto:info@carrellispeciali.it) ✉

# SBC XT HD 5025

CS Italia s.r.l.

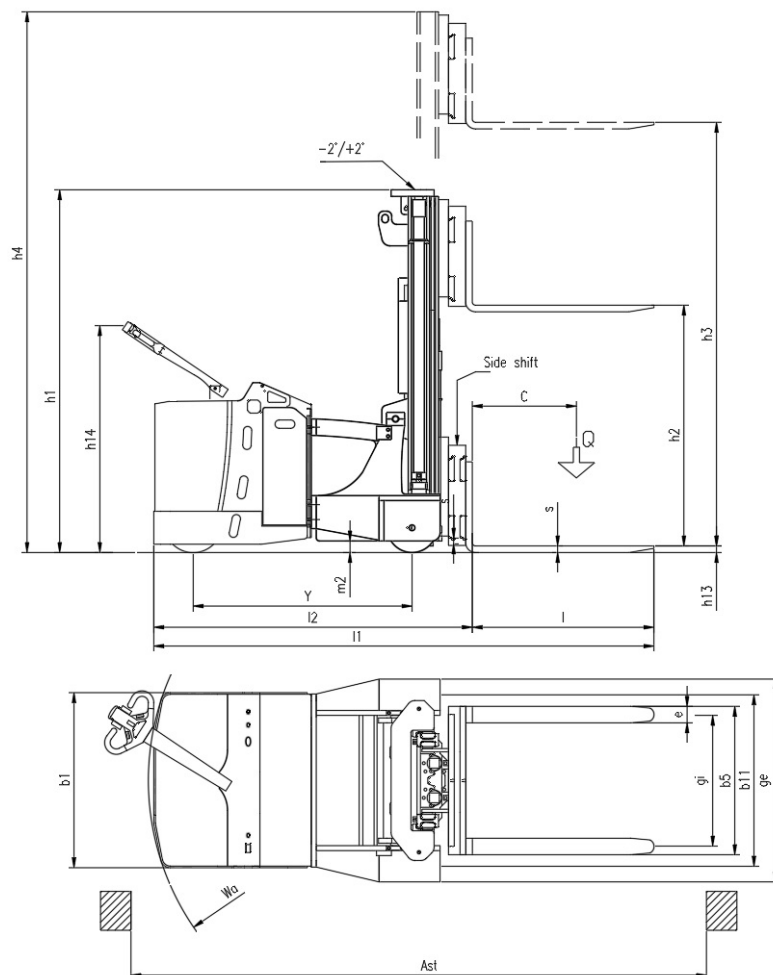

Illustrazioni e dati tecnici non sono impegnativi. Il costruttore si riserva il diritto di apportare modifiche senza preavviso.

**Tipologia** SBC XT HD 5025

**Categoria** Contrappesati

<b>General info</b>	1.1	Manufacturer			CSI s.r.l.
	1.2	Model			SBC XT HD 5025
	1.3	Drive			elettrico AC
	1.4	Operator type			a timone
	1.5	Load capacity	Q	t	2.5
	1.6	Load centre	c	mm	600
	1.9	Wheelbase	y	mm	1325
<b>Weights</b>	2.1	Truck weight without battery		Kg	4300
<b>Wheels and chassis</b>	3.1	Wheels			Poliuretano
	3.2	Wheels size front		mm	350x140
	3.3	Wheels size rear		mm	300x70
	3.5	Number of rear/front wheels (x = Traction wheel)			1x/2+2
	3.7	Rear wheelbase	b11	mm	1040
	3.9	Overall width legs	ge	mm	1230
	3.10	Inside width legs	gi	mm	790
<b>Dimensions</b>	4.1	Tilt		°	-1/+2
	4.2	Height mast lowered	h1	mm	2450
	4.3	Free lift	h2	mm	1730
	4.4	Lift height	h3	mm	4950
	4.5	Height mast extended	h4	mm	5650
	4.9	Height of tiller (min/max)	h14	mm	975/1535
	4.15	Height forks lowered	h13	mm	50
	4.19	Overall length	l1	mm	3130
	4.20	Length to face of forks	l2	mm	1930
	4.21	Overall width	b1	mm	1062
	4.22	Forks dimensions	s/e/l	mm	45/120/1200
	4.23	Carriage forks			FEM 2A
	4.25	Overall forks width size	b5	mm	240-780
	4.31	Ground clearance		mm	40
	4.34	Aisle width	ast	mm	3420
4.35	Turning radius	wa	mm	1580	
<b>Performance</b>	5.1	Travel speed with/without load		Km/h	3/5
	5.2	Lifting speed with/without load		m/s	0,11/0,33
	5.3	Lowering speed with/without load		m/s	0,5/0,2
	5.8	Maximum gradeability with/without load		%	1/3
	5.10	Service brake			elettrico
<b>Motor</b>	6.1	Traction motor S2 60 min.		Kw	3
	6.2	Lift motor S3		Kw	3
	6.3	Battery			no
	6.4	Battery - voltage and nominal capacity		V/Ah	24V/420 Ah
	6.5	Battery weight		Kg	340
	Dim. batteria	Battery size		mm	1015x255x575
<b>Other</b>	8.1	Traction control			proporzionale
	8.4	Noise level driver place			<70