

**SBP TX 1112**

CS Italia s.r.l.

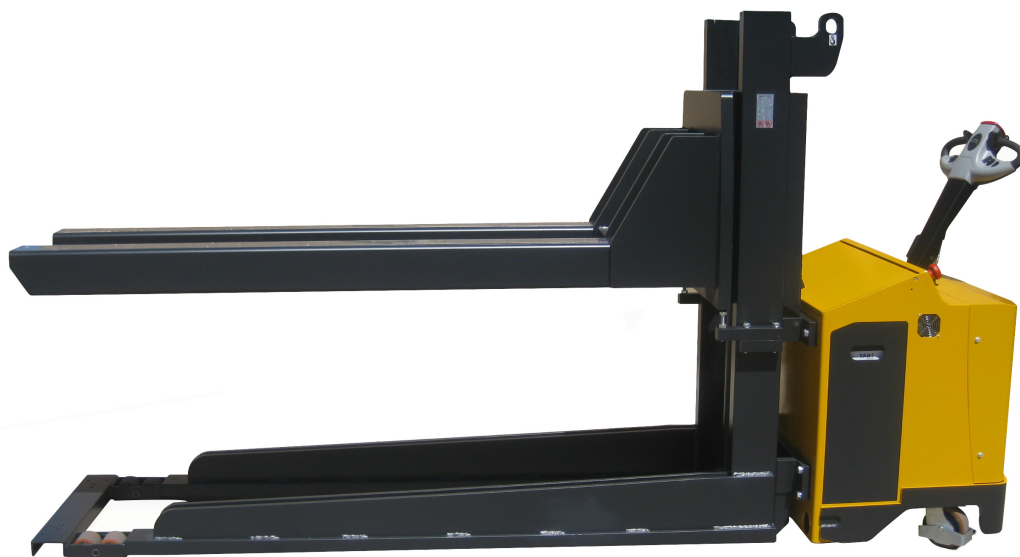

Optional su richiesta [info@carrellispeciali.it](mailto:info@carrellispeciali.it) 

# SBP TX 1112

CS Italia s.r.l.

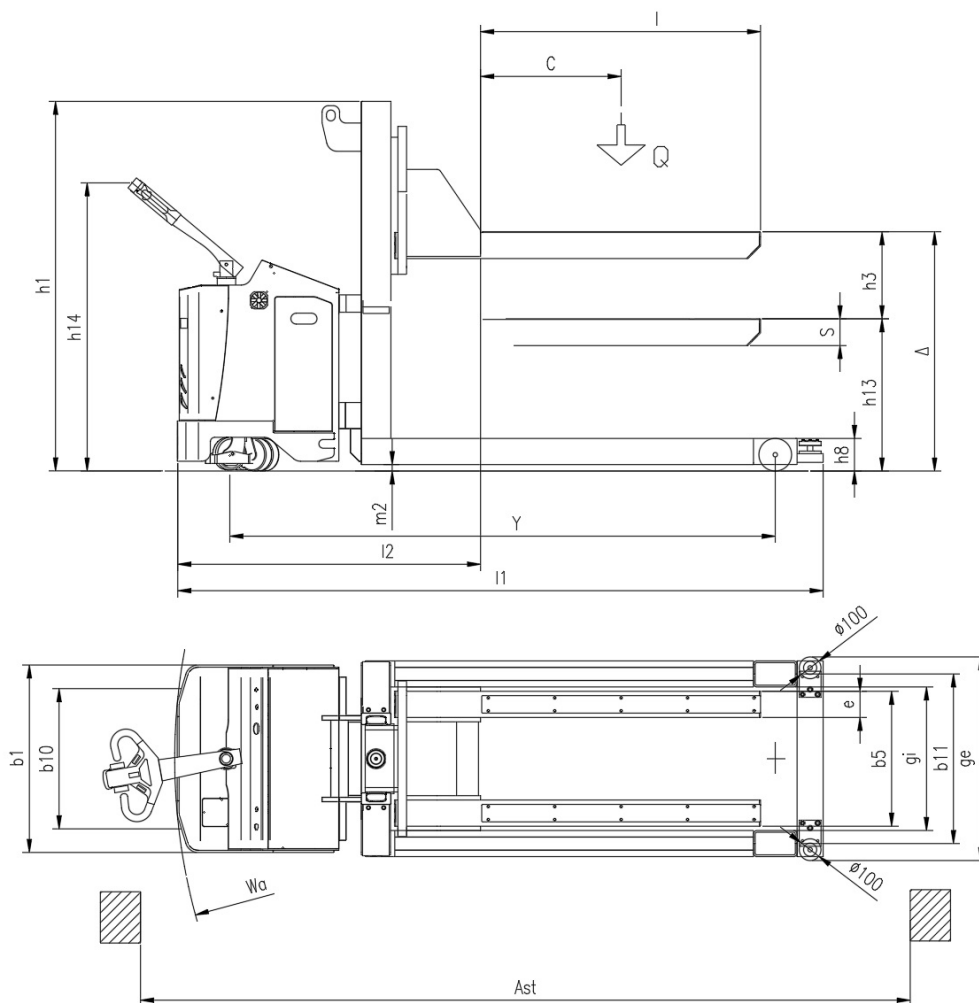

Illustrazioni e dati tecnici non sono impegnativi. Il costruttore si riserva il diritto di apportare modifiche senza preavviso.

**Tipologia** SBP TX 1112

**Categoria**

<b>General info</b>	1.1	Manufacturer			CSI s.r.l.
	1.2	Model			SBP TX 1112
	1.3	Drive			elettrico DC
	1.4	Operator type			a timone
	1.5	Load capacity	Q	t	1.2
	1.6	Load centre	c	mm	650
	1.9	Wheelbase	y	mm	2500
<b>Weights</b>	2.1	Truck weight without battery		Kg	1300
<b>Wheels and chassis</b>	3.1	Wheels			Poliuretano
	3.2	Wheels size front		mm	250x100
	3.3	Wheels size rear		mm	150x50
	3.4	Additional wheels size		mm	150X50
	3.5	Number of rear/front wheels (x = Traction wheel)			1X+2 / 2+2
	3.6	Front wheelbase	b10	mm	650
	3.7	Rear wheelbase	b11	mm	780
	3.9	Overall width legs	ge	mm	940
	3.10	Inside width legs	gi	mm	660
	3.11	Legs height	h8	mm	150
	<b>Dimensions</b>	4.2	Height mast lowered	h1	mm
4.4		Lift height	h3	mm	400
4.9		Height of tiller (min/max)	h14	mm	975/1535
4.15		Height forks lowered	h13	mm	700
4.19		Overall length	l1	mm	2960
4.20		Length to face of forks	l2	mm	1390
4.21		Overall width	b1	mm	862
4.22		Forks dimensions	s/e/l	mm	120/120/1285
4.25		Overall forks width size	b5	mm	620
4.31		Ground clearance		mm	40
4.34		Aisle width	ast	mm	3540
4.35		Turning radius	wa	mm	2760
<b>Performance</b>		5.1	Travel speed with/without load		Km/h
	5.2	Lifting speed with/without load		m/s	0.11/0.33
	5.3	Lowering speed with/without load		m/s	0.5/0.2
	5.8	Maximum gradeability with/without load		%	1/3
	5.10	Service brake			elettrico
<b>Motor</b>	6.1	Traction motor S2 60 min.		Kw	1.7
	6.2	Lift motor S3		Kw	3
	6.3	Battery			Piombo acido
	6.4	Battery - voltage and nominal capacity		V/Ah	24V / 240Ah
	6.5	Battery weight		Kg	210
	Dim. batteria	Battery size		mm	810/257/450
<b>Other</b>	8.1	Traction control			proporzionale
	8.4	Noise level driver place			<70