

TR XT HD 120

CS Italia s.r.l.



Optional su richiesta info@carrellispeciali.it 

TR XT HD 120

CS Italia s.r.l.

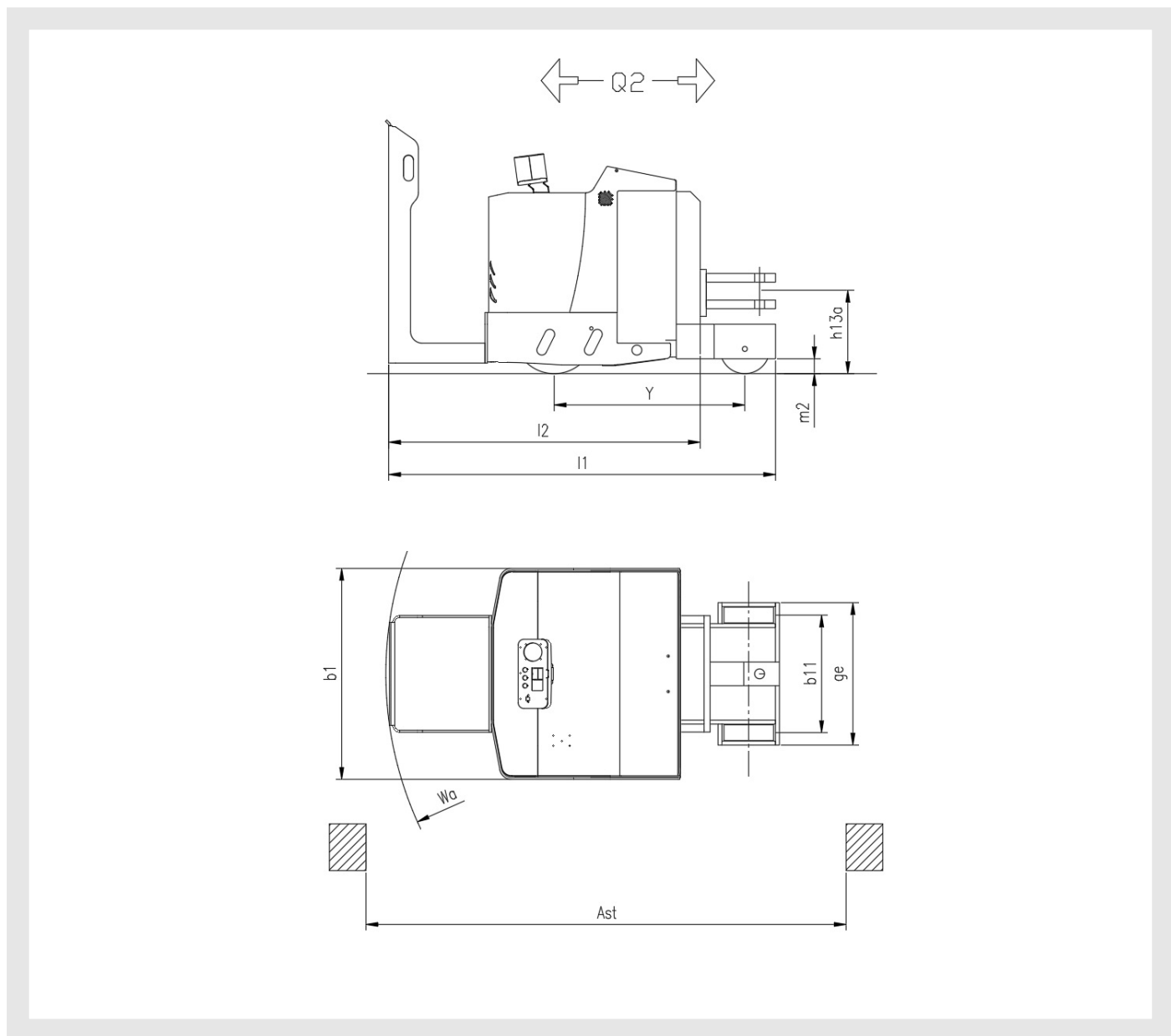

Illustrazioni e dati tecnici non sono impegnativi. Il costruttore si riserva il diritto di apportare modifiche senza preavviso.

Tipologia TR XT HD 120

Categoria

General info	1.1	Manufacturer			CSI s.r.l.
	1.2	Model			TR XT HD 120
	1.3	Drive			elettrico AC
	1.4	Operator type			a volante
	1.5a	Towing capacity	Q1	t	12
	1.9	Wheelbase	y	mm	960
Weights	2.1	Truck weight without battery		Kg	3100
Wheels and chassis	3.1	Wheels			Poliuretano
	3.2	Wheels size front		mm	350x140
	3.3	Wheels size rear		mm	250x50
	3.7	Rear wheelbase	b11	mm	595
	3.9	Overall width legs	ge	mm	750
Dimensions	4.12	Tow pin diameter	Øp	mm	40
	4.15a	Tow hook height from the ground	h13a	mm	420
	4.19	Overall length	l1	mm	1960
	4.20	Length to face of forks	l2	mm	1570
	4.21	Overall width	b1	mm	1076
	4.35	Turning radius	wa	mm	1850
Performance	5.1	Travel speed with/without load		Km/h	3/5
	5.8	Maximum gradeability with/without load		%	1/3
	5.10	Service brake			elettrico
Motor	6.1	Traction motor S2 60 min.		Kw	5
	6.3	Battery			Piombo acido
	6.4	Battery - voltage and nominal capacity		V/Ah	48V 250Ah
	6.5	Battery weight		Kg	420
	Dim. batteria	Battery size		mm	1015/255/627
Other	8.1	Traction control			proporzionale
	8.4	Noise level driver place			<70