

**K9 SOB XT 60**

CS Italia s.r.l.



Optional su richiesta [info@carrellispeciali.it](mailto:info@carrellispeciali.it) 

# K9 SOB XT 60

CS Italia s.r.l.

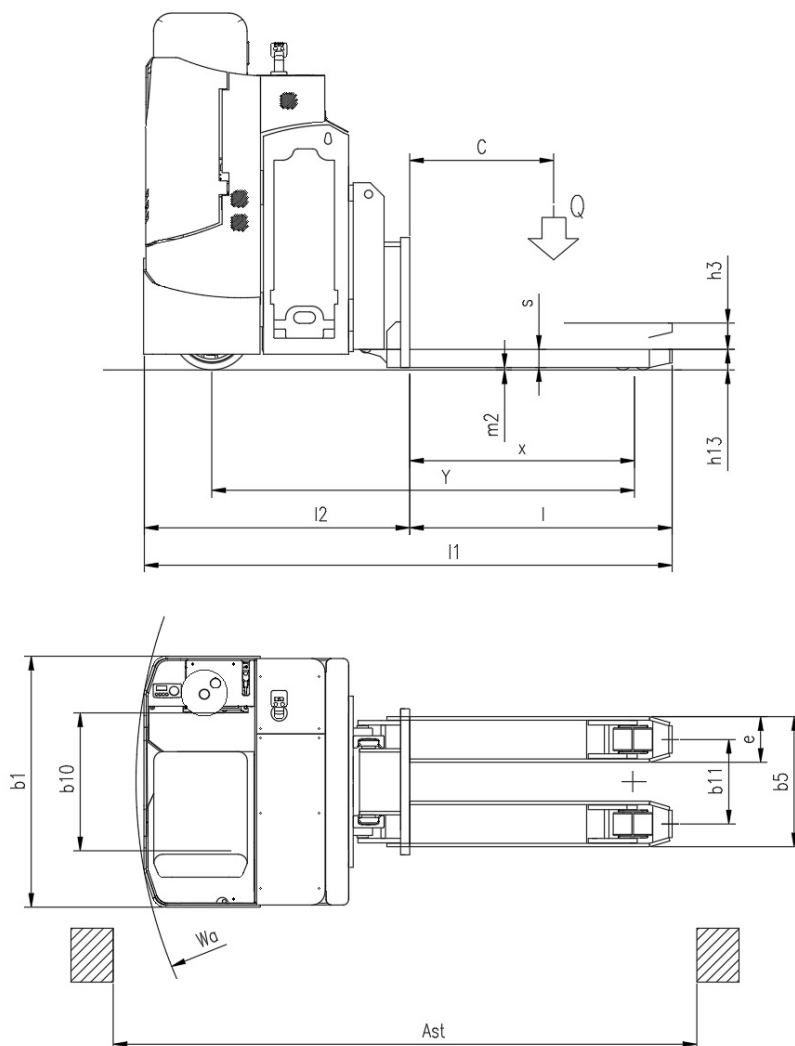

Illustrazioni e dati tecnici non sono impegnativi. Il costruttore si riserva il diritto di apportare modifiche senza preavviso.

**Tipologia** K9 SOB XT 60

**Categoria** Transpallet

<b>General info</b>	1.1	Manufacturer			CSI s.r.l.
	1.2	Model			K9 SOB XT 60
	1.3	Drive			elettrico AC
	1.4	Operator type			Volante
	1.5	Load capacity	Q	t	6
	1.8	Load distance to wheel axle	x	mm	985
	1.9	Wheelbase	y	mm	1852
	<b>Weights</b>				
2.1	Truck weight without battery			Kg	1050
<b>Wheels and chassis</b>					
3.1	Wheels				Poliuretano
3.2	Wheels size front			mm	254x100
3.3	Wheels size rear			mm	80x100
3.4	Additional wheels size			mm	150x50
3.5	Number of rear/front wheels (x = Traction wheel)				1x/2+2/4
3.6	Front wheelbase	b10		mm	600
3.7	Rear wheelbase	b11		mm	370
<b>Dimensions</b>					
4.4	Lift height	h3		mm	115
4.15	Height forks lowered	h13		mm	90
4.20	Length to face of forks	l2		mm	1185
4.21	Overall width	b1		mm	1100
4.22	Forks dimensions	s/e/l		mm	70/200/1150
4.25	Overall forks width size	b5		mm	570
4.32	Distanza da piano di lavoro a inizio forza	m2		mm	20
4.34	Aisle width	ast		mm	2585
4.35	Turning radius	wa		mm	2195
<b>Performance</b>					
5.1	Travel speed with/without load			Km/h	5/6
5.2	Lifting speed with/without load			m/s	0.11/0.33
5.3	Lowering speed with/without load			m/s	0.5/0.2
5.8	Maximum gradeability with/without load			%	3/5
5.10	Service brake				elettrico
<b>Motor</b>					
6.1	Traction motor S2 60 min.			Kw	2.5
6.2	Lift motor S3			Kw	2.2
6.3	Battery				Piombo acido
6.4	Battery - voltage and nominal capacity			V/Ah	24V 420Ah
6.5	Battery weight			Kg	370
Dim. batteria	Battery size			mm	1015/257/575
<b>Other</b>					
8.1	Traction control				proporzionale
8.4	Noise level driver place				<70