

K9 SBM XT HD 80

CS Italia s.r.l.



Optional su richiesta info@carrellispeciali.it 

K9 SBM XT HD 80

CS Italia s.r.l.

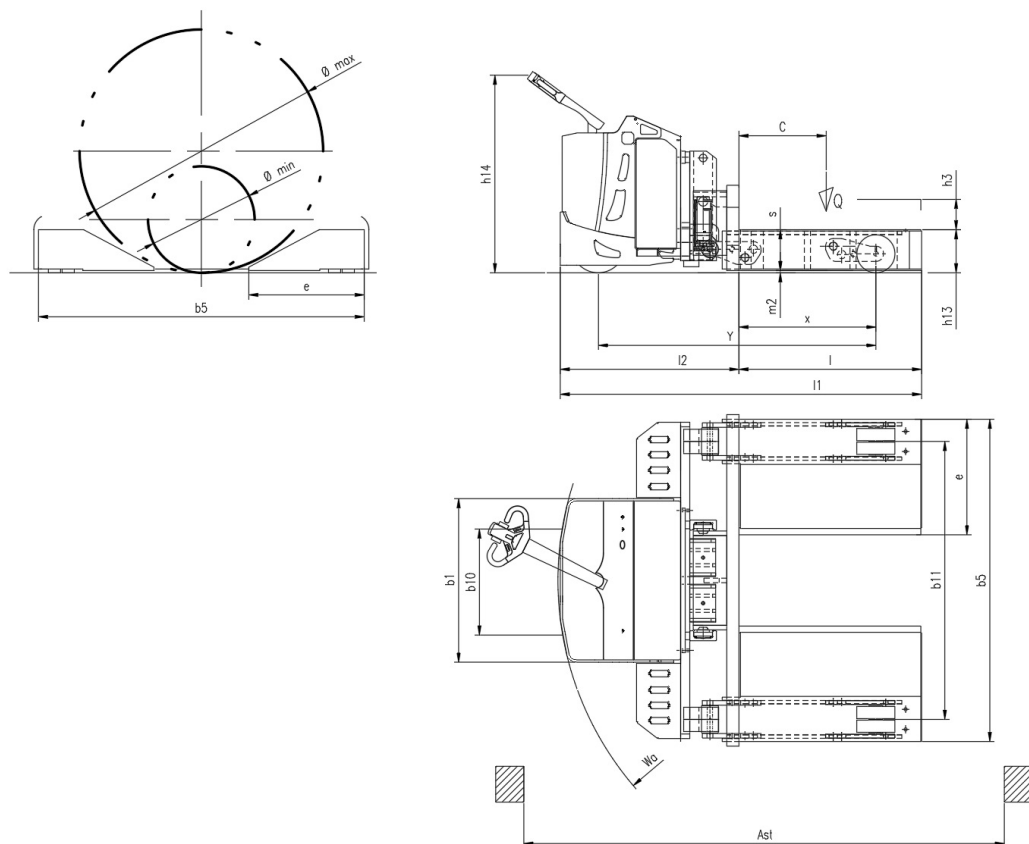

Illustrazioni e dati tecnici non sono impegnativi. Il costruttore si riserva il diritto di apportare modifiche senza preavviso.

Tipologia K9 SBM XT HD 80

Categoria

General info	1.1	Manufacturer			CSI s.r.l.
	1.2	Model			K9 SBM XT HD 80
	1.3	Drive			elettrico AC
	1.4	Operator type			a timone
	1.5	Load capacity	Q	t	8
	1.6	Load centre	c	mm	600
	1.8	Load distance to wheel axle	x	mm	900
	1.9	Wheelbase	y	mm	1825
	Weights	2.1	Truck weight without battery		Kg
Wheels and chassis	3.1	Wheels			Poliuretano
	3.2	Wheels size front		mm	350x140
	3.3	Wheels size rear		mm	250X80
	3.4	Additional wheels size		mm	200x80
	3.5	Number of rear/front wheels (x = Traction wheel)			1x+2/2+2
	3.6	Front wheelbase	b10	mm	600
	3.7	Rear wheelbase	b11	mm	1830
Dimensions	4.4	Lift height	h3	mm	200
	4.9	Height of tiller (min/max)	h14	mm	975/1535
	4.13	Minimum diameter	Ø min	mm	700
	4.14	Maximum diameter	Ø max	mm	1600
	4.15	Height forks lowered	h13	mm	285
	4.19	Overall length	l1	mm	2980
	4.20	Length to face of forks	l2	mm	1180
	4.21	Overall width	b1	mm	1076
	4.22	Forks dimensions	s/e/l	mm	270/760/1200
	4.25	Overall forks width size	b5	mm	2120
	4.31	Ground clearance		mm	40
	4.32	Distanza da piano di lavoro a inizio forca	m2	mm	15
	4.34	Aisle width	ast	mm	3250
	4.35	Turning radius	wa	mm	2090
	Performance	5.2	Lifting speed with/without load		m/s
5.3		Lowering speed with/without load		m/s	0.5/0.2
5.8		Maximum gradeability with/without load		%	1/3
5.10		Service brake			elettrico
Motor	6.1	Traction motor S2 60 min.		Kw	5
	6.2	Lift motor S3		Kw	2
	6.3	Battery			Piombo acido
	6.4	Battery - voltage and nominal capacity		V/Ah	48V 250Ah
	6.5	Battery weight		Kg	420
	Dim. batteria	Battery size		mm	1015/255/627
Other	8.1	Traction control			proporzionale
	8.4	Noise level driver place			<70