

**SBP TX 3220 SPO**

CS Italia s.r.l.



Optional su richiesta [info@carrellispeciali.it](mailto:info@carrellispeciali.it) ✉

# SBP TX 3220 SP0

CS Italia s.r.l.

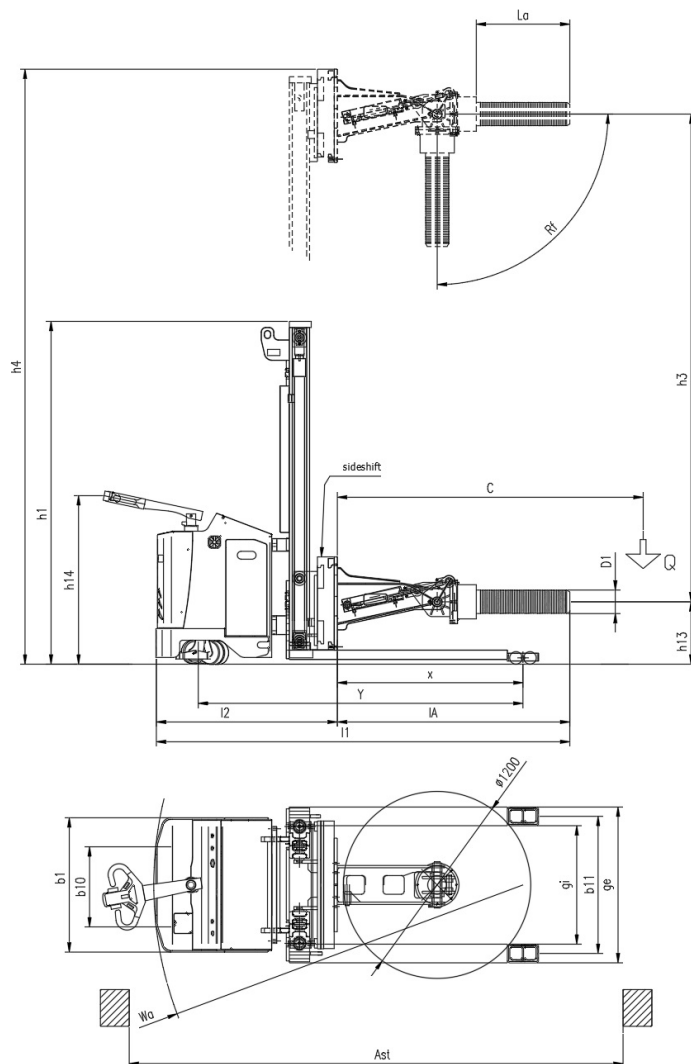

Illustrazioni e dati tecnici non sono impegnativi. Il costruttore si riserva il diritto di apportare modifiche senza preavviso.

**Tipologia** SBP TX 3220 SP0

**Categoria**

<b>General info</b>	1.1	Manufacturer			CSI s.r.l.
	1.2	Model			SBP TX 3220 SPO
	1.3	Drive			elettrico AC
	1.4	Operator type			a timone
	1.5	Load capacity	Q	t	0.6
	1.6	Load centre	c	mm	2000
	1.8	Load distance to wheel axle	x	mm	1190
	1.9	Wheelbase	y	mm	2080
	<b>Weights</b>				
	2.1	Truck weight without battery		Kg	2200
<b>Wheels and chassis</b>					
	3.1	Wheels			Poliuretano
	3.2	Wheels size front		mm	250x100
	3.3	Wheels size rear		mm	80X80
	3.4	Additional wheels size		mm	150X50
	3.5	Number of rear/front wheels (x = Traction wheel)			1x+2/2+2
	3.6	Front wheelbase	b10	mm	500
	3.7	Rear wheelbase	b11	mm	880
	3.9	Overall width legs	ge	mm	1000
	3.10	Inside width legs	gi	mm	760
	3.12	Front rotation	Rf	°	90
<b>Dimensions</b>					
	4.2	Height mast lowered	h1	mm	1790
	4.4	Lift height	h3	mm	3100
	4.5	Height mast extended	h4	mm	3800
	4.9	Height of tiller (min/max)	h14	mm	975/1535
	4.15	Height forks lowered	h13	mm	300
	4.19	Overall length	l1	mm	2650
	4.20	Length to face of forks	l2	mm	1160
	4.21	Overall width	b1	mm	862
	4.22c	Size of the reel	La/Lb/D1/D2	mm - Ø	600/148
	4.23	Carriage forks			FEM 3A
	4.31	Ground clearance		mm	40
	4.34	Aisle width	ast	mm	3150
	4.35	Turning radius	wa	mm	2370
<b>Performance</b>					
	5.1	Travel speed with/without load		Km/h	3/5
	5.2	Lifting speed with/without load		m/s	0.11/0.33
	5.3	Lowering speed with/without load		m/s	0.5/0.2
	5.8	Maximum gradeability with/without load		%	1/3
	5.10	Service brake			elettrico
<b>Motor</b>					
	6.1	Traction motor S2 60 min.		Kw	2.5
	6.2	Lift motor S3		Kw	3
	6.3	Battery			Piombo acido
	6.4	Battery - voltage and nominal capacity		V/Ah	24V 210Ah
	6.5	Battery weight		Kg	210
	Dim. batteria	Battery size		mm	810/210/450
<b>Other</b>					
	8.1	Traction control			proporzionale
	8.4	Noise level driver place			<70

