

**SBP XT HD 1890**

CS Italia s.r.l.

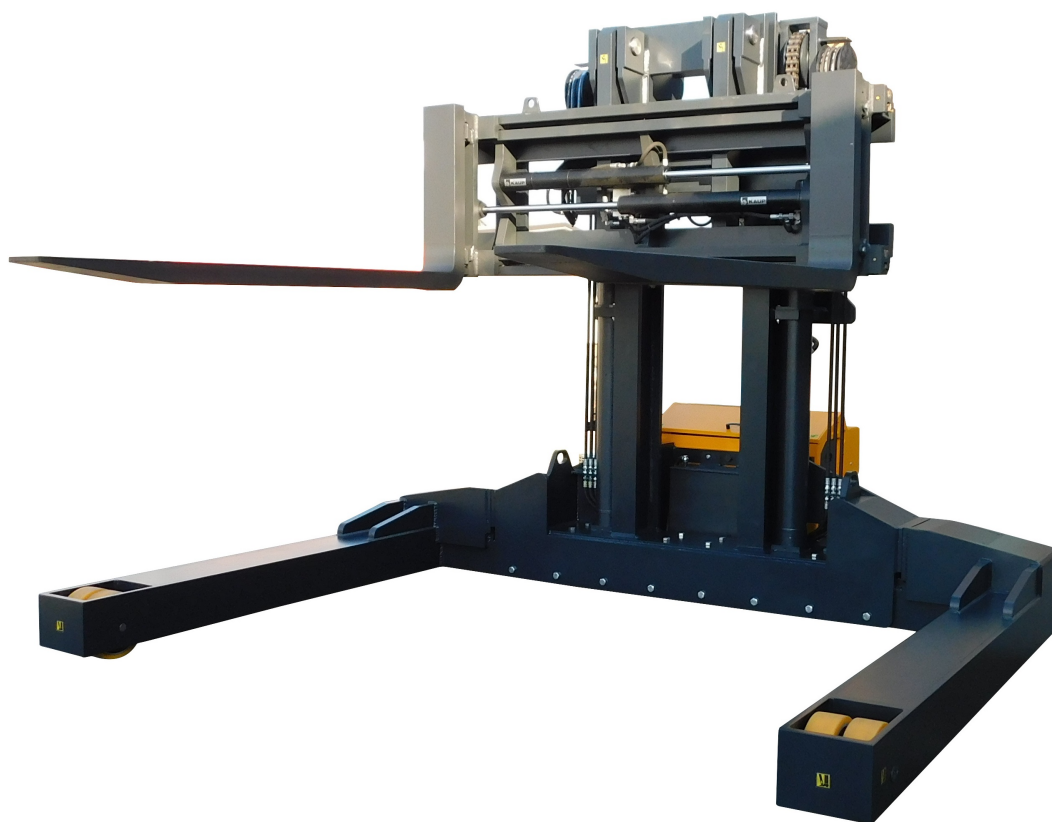

Optional su richiesta [info@carrellispeciali.it](mailto:info@carrellispeciali.it) 

# SBP XT HD 1890

CS Italia s.r.l.

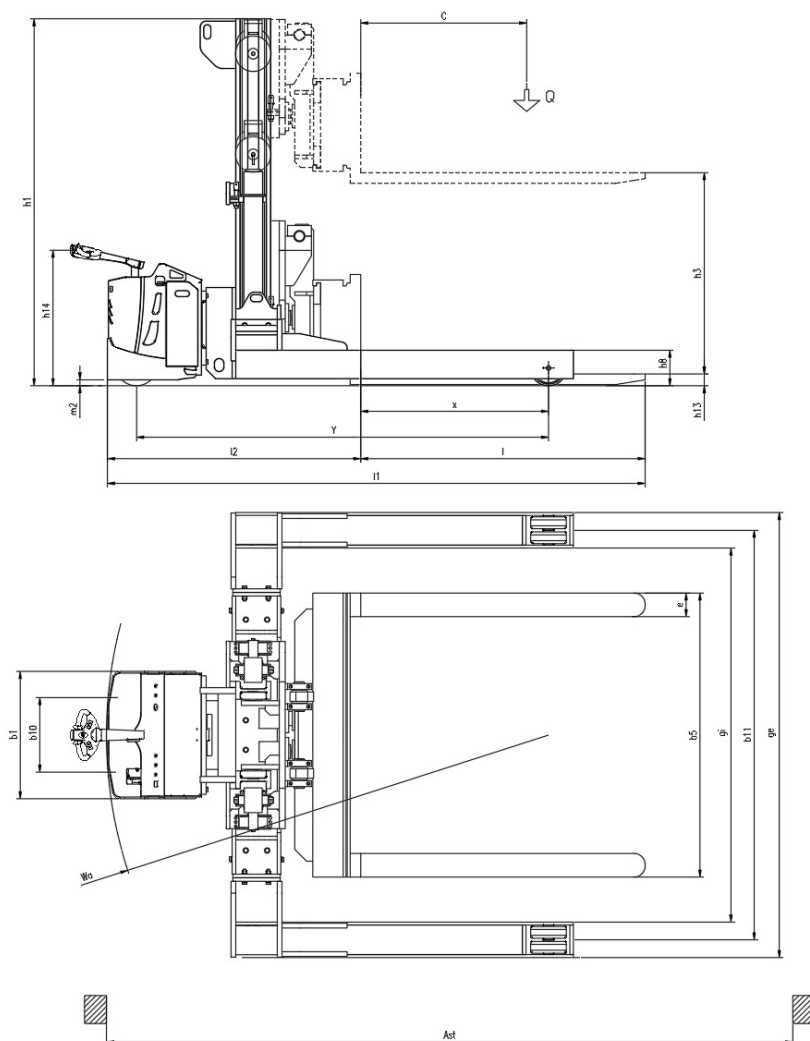

Illustrazioni e dati tecnici non sono impegnativi. Il costruttore si riserva il diritto di apportare modifiche senza preavviso.

**Tipologia** SBP XT HD 1890

**Categoria**

<b>General info</b>	1.1	Manufacturer			CSI s.r.l.
	1.2	Model			SBP XT HD 1890
	1.3	Drive			elettrico AC
	1.4	Operator type			a timone
	1.5	Load capacity	Q	t	9
	1.6	Load centre	c	mm	1400
	1.8	Load distance to wheel axle	x	mm	1560
	1.9	Wheelbase	y	mm	3480
	<b>Weights</b>				
	2.1	Truck weight without battery		Kg	1600
<b>Wheels and chassis</b>					
	3.1	Wheels			Poliuretano
	3.2	Wheels size front		mm	350x140
	3.3	Wheels size rear		mm	300X100
	3.4	Additional wheels size		mm	200X80
	3.5	Number of rear/front wheels (x = Traction wheel)			1x+2/2+2
	3.6	Front wheelbase	b10	mm	600
	3.7	Rear wheelbase	b11	mm	3460
	3.9	Overall width legs	ge	mm	3760
	3.10	Inside width legs	gi	mm	3160
	3.11	Legs height	h8	mm	300
<b>Dimensions</b>					
	4.1	Tilt		°	3
	4.2	Height mast lowered	h1	mm	3100
	4.4	Lift height	h3	mm	1700
	4.9	Height of tiller (min/max)	h14	mm	975/1535
	4.15	Height forks lowered	h13	mm	100
	4.19	Overall length	l1	mm	5450
	4.20	Length to face of forks	l2	mm	2140
	4.21	Overall width	b1	mm	1076
	4.22	Forks dimensions	s/e/l	mm	80/200/2400
	4.23	Carriage forks			FEM 5A
	4.25	Overall forks width size	b5	mm	460-2400
	4.31	Ground clearance		mm	50
	4.32	Distanza da piano di lavoro a inizio forca	m2	mm	50
	4.34	Aisle width	ast	mm	5800
	4.35	Turning radius	wa	mm	3730
<b>Performance</b>					
	5.1	Travel speed with/without load		Km/h	3/5
	5.2	Lifting speed with/without load		m/s	0.11/0.33
	5.3	Lowering speed with/without load		m/s	0.5/0.2
	5.8	Maximum gradeability with/without load		%	1/3
	5.10	Service brake			elettrico
<b>Motor</b>					
	6.1	Traction motor S2 60 min.		Kw	5
	6.2	Lift motor S3		Kw	7
	6.3	Battery			Piombo acido
	6.4	Battery - voltage and nominal capacity		V/Ah	48V 250Ah
	6.5	Battery weight		Kg	420
	Dim. batteria	Battery size		mm	1015/255/627

## DATI TECNICI

Other	8.1	Traction control		proporzionale
	8.4	Noise level driver place		<70