

**K9 SBM XT HD 100**

CS Italia s.r.l.



Optional su richiesta [info@carrellispeciali.it](mailto:info@carrellispeciali.it) ✉

# K9 SBM XT HD 100

CS Italia s.r.l.

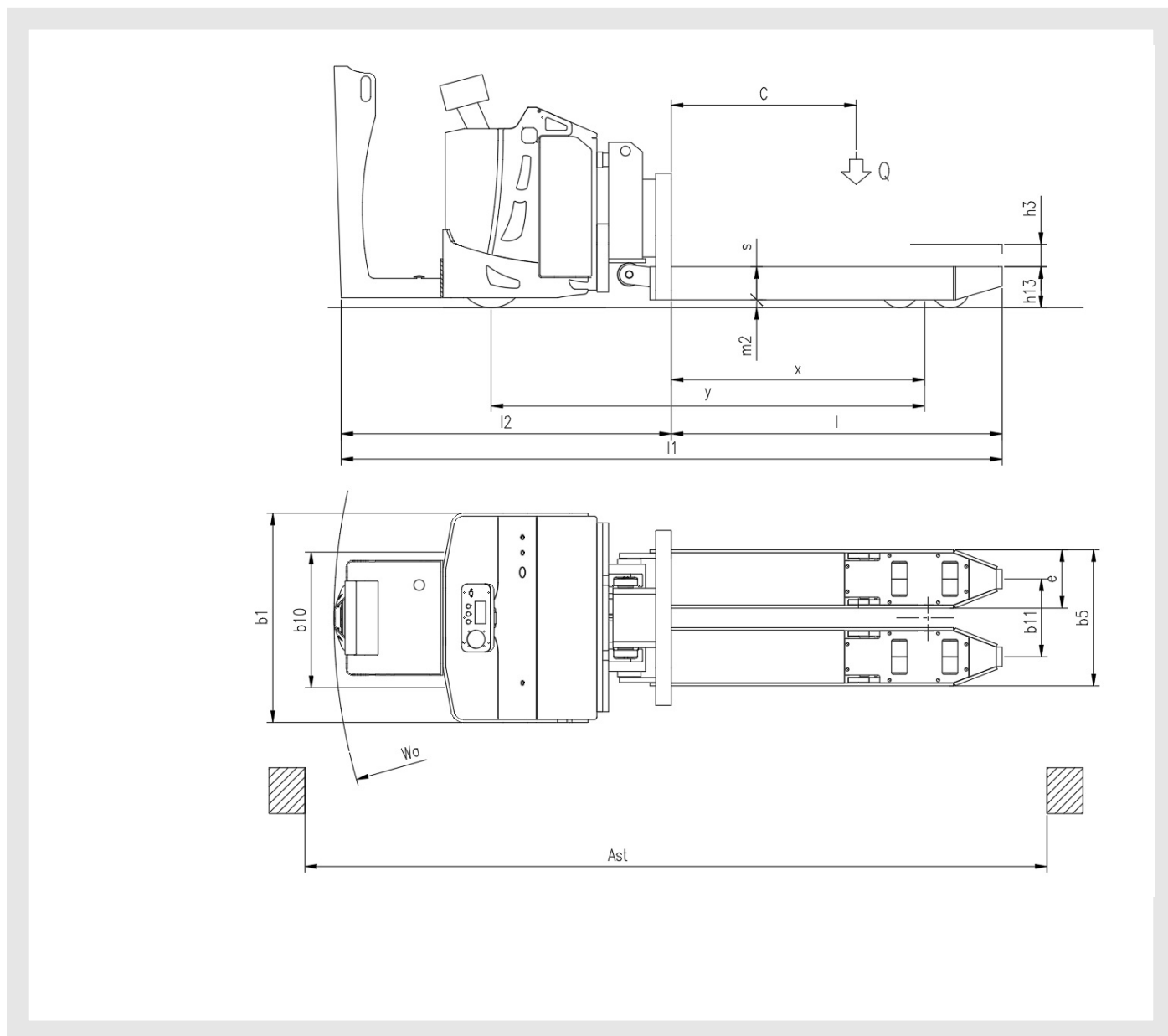

Illustrazioni e dati tecnici non sono impegnativi. Il costruttore si riserva il diritto di apportare modifiche senza preavviso.

**Tipologia** K9 SBM XT HD 100

**Categoria** Transpallet

<b>General info</b>	1.1	Manufacturer			CSI s.r.l.
	1.2	Model			K9 SBM XT HD 100
	1.3	Drive			elettrico AC
	1.4	Operator type			a volante
	1.5	Load capacity	Q	t	10
	1.6	Load centre	c	mm	1000
	1.8	Load distance to wheel axle	x	mm	1300
	1.9	Wheelbase	y	mm	2225
	<b>Weights</b>	2.1	Truck weight without battery		Kg
<b>Wheels and chassis</b>	3.1	Wheels			Poliuretano
	3.2	Wheels size front		mm	350x140
	3.3	Wheels size rear		mm	200x80
	3.4	Additional wheels size		mm	200x80
	3.5	Number of rear/front wheels (x = Traction wheel)			1x+2/2+2
	3.6	Front wheelbase	b10	mm	600
	3.7	Rear wheelbase	b11	mm	820
<b>Dimensions</b>	4.4	Lift height	h3	mm	115
	4.15	Height forks lowered	h13	mm	200
	4.19	Overall length	l1	mm	2400
	4.20	Length to face of forks	l2	mm	1180
	4.21	Overall width	b1	mm	1076
	4.22	Forks dimensions	s/e/l	mm	170/300/1700
	4.25	Overall forks width size	b5	mm	700
	4.31	Ground clearance		mm	40
	4.32	Distanza da piano di lavoro a inizio forca	m2	mm	30
4.35	Turning radius	wa	mm	3050	
<b>Performance</b>	5.1	Travel speed with/without load		Km/h	3/6
	5.2	Lifting speed with/without load		m/s	0.11/0.33
	5.3	Lowering speed with/without load		m/s	0.5/0.2
	5.8	Maximum gradeability with/without load		%	1/3
	5.10	Service brake			elettrico
<b>Motor</b>	6.1	Traction motor S2 60 min.		Kw	5
	6.2	Lift motor S3		Kw	2
	6.3	Battery			Piombo acido
	6.4	Battery - voltage and nominal capacity		V/Ah	48V 250Ah
	6.5	Battery weight		Kg	420
	Dim. batteria	Battery size		mm	1015/255/627
<b>Other</b>	8.1	Traction control			proporzionale
	8.4	Noise level driver place			<70