

K9 SBM XT HB

CS Italia s.r.l.

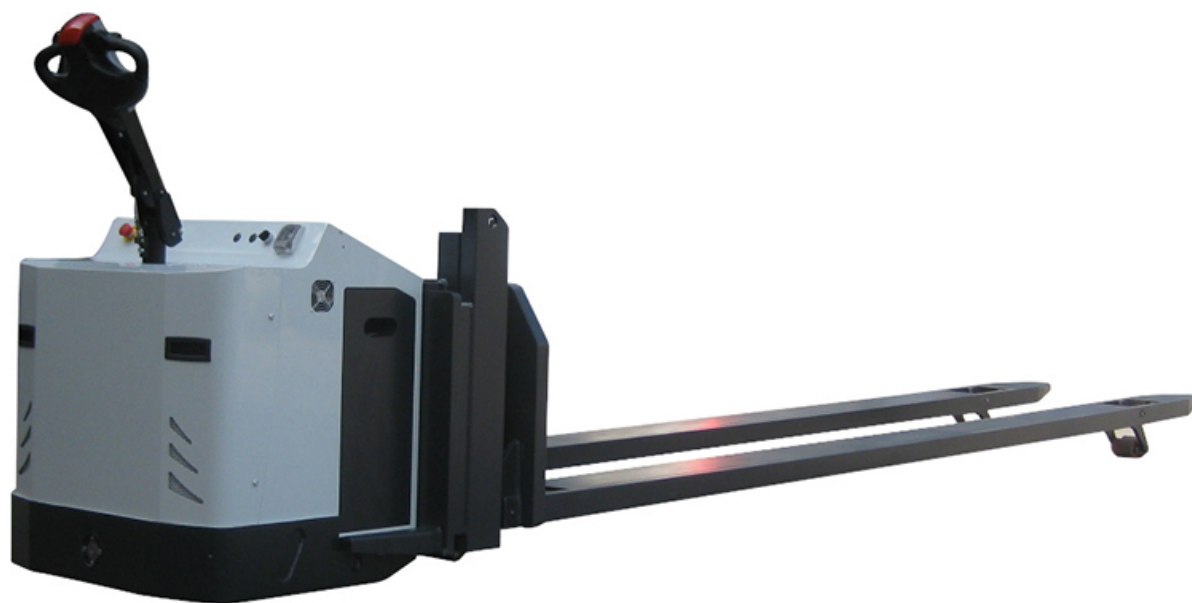

Optional su richiesta info@carrellispeciali.it 

K9 SBM XT HB

CS Italia s.r.l.

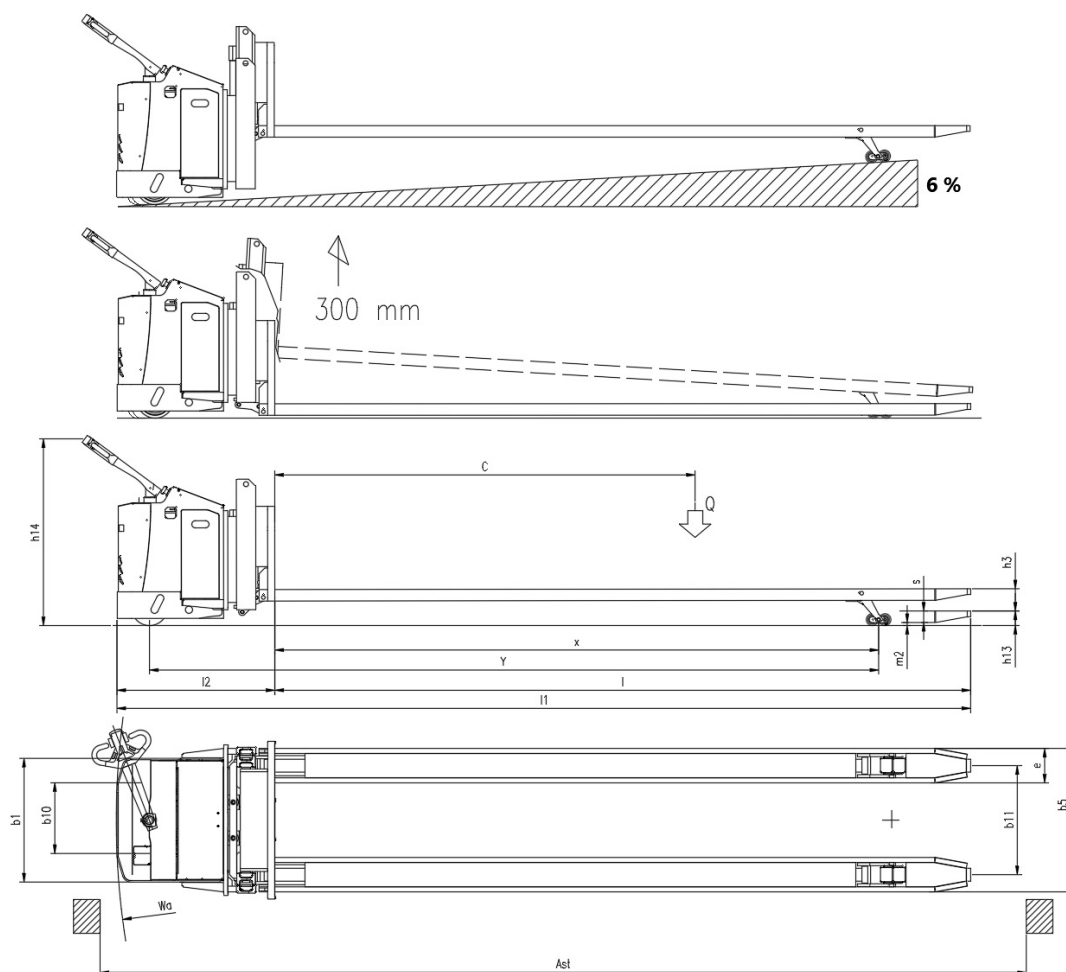

Illustrazioni e dati tecnici non sono impegnativi. Il costruttore si riserva il diritto di apportare modifiche senza preavviso.

Tipologia K9 SBM XT HB

Categoria Transpallet

General info	1.1	Manufacturer			CSI s.r.l.
	1.2	Model			K9 SBM XT HB
	1.3	Drive			elettrico AC
	1.4	Operator type			a timone
	1.5	Load capacity	Q	t	3.5
	1.6	Load centre	c	mm	2930
	1.8	Load distance to wheel axle	x	mm	4210
	1.9	Wheelbase	y	mm	1760
	Weights				
	2.1	Truck weight without battery		Kg	700
Wheels and chassis					
	3.1	Wheels			Poliuretano
	3.2	Wheels size front		mm	254x100
	3.3	Wheels size rear		mm	80x100
	3.4	Additional wheels size		mm	150x50
	3.5	Number of rear/front wheels (x = Traction wheel)			1x+2/2+2
	3.6	Front wheelbase	b10	mm	500
	3.7	Rear wheelbase	b11	mm	760
Dimensions					
	4.4	Lift height	h3	mm	150
	4.9	Height of tiller (min/max)	h14	mm	975/1535
	4.15	Height forks lowered	h13	mm	100
	4.19	Overall length	l1	mm	5950
	4.20	Length to face of forks	l2	mm	1100
	4.21	Overall width	b1	mm	862
	4.22	Forks dimensions	s/e/l	mm	80/240/4850
	4.25	Overall forks width size	b5	mm	1000
	4.32	Distanza da piano di lavoro a inizio forca	m2	mm	20
	4.35	Turning radius	wa	mm	5445
Performance					
	5.1	Travel speed with/without load		Km/h	3/6
	5.2	Lifting speed with/without load		m/s	0,04/0,05
	5.3	Lowering speed with/without load		m/s	0,26/0,06
	5.8	Maximum gradeability with/without load		%	6
	5.10	Service brake			elettrico
Motor					
	6.1	Traction motor S2 60 min.		Kw	2.5
	6.2	Lift motor S3		Kw	2.2
	6.3	Battery			Piombo acido
	6.4	Battery - voltage and nominal capacity		V/Ah	24V 420Ah
	6.5	Battery weight		Kg	370
	Dim. batteria	Battery size		mm	810/257/575
Other					
	8.1	Traction control			proporzionale
	8.4	Noise level driver place			<70