

**K9 SOB XT 40**

CS Italia s.r.l.



Optional su richiesta [info@carrellispeciali.it](mailto:info@carrellispeciali.it) 

# K9 SOB XT 40

CS Italia s.r.l.

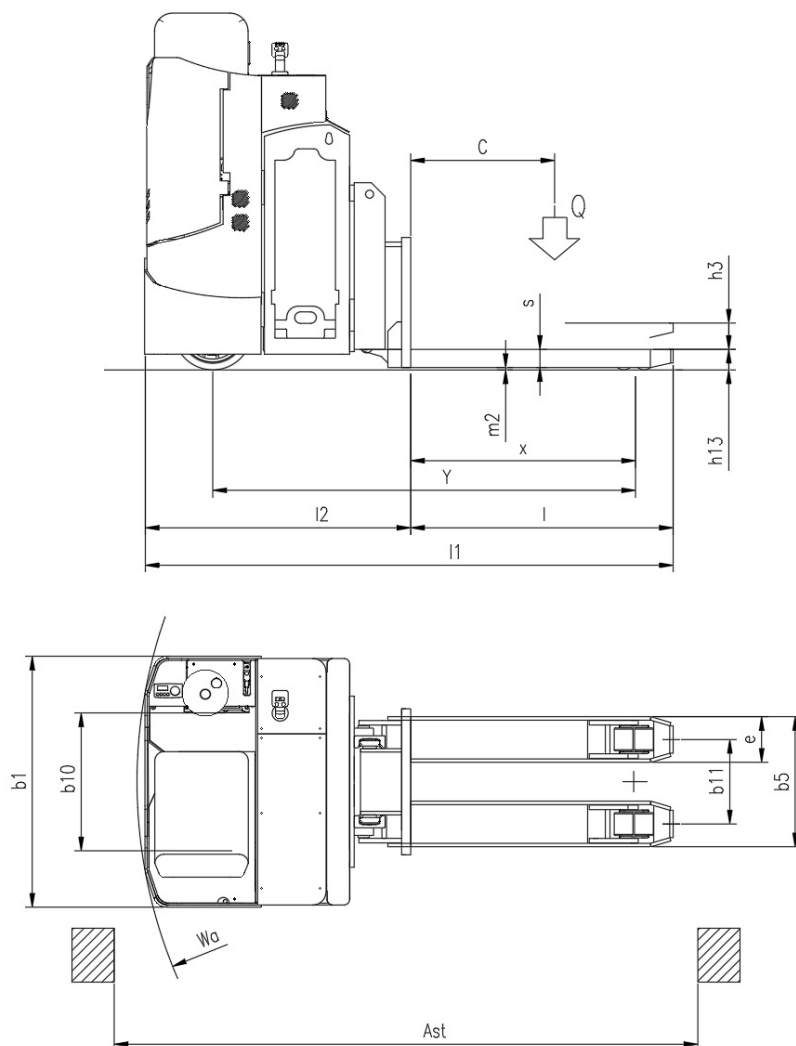

Illustrazioni e dati tecnici non sono impegnativi. Il costruttore si riserva il diritto di apportare modifiche senza preavviso.

**Tipologia** K9 SOB XT 40

**Categoria** Transpallet

<b>General info</b>	1.1	Manufacturer			CSI s.r.l.
	1.2	Model			K9 SOB XT 40
	1.3	Drive			elettrico AC
	1.4	Operator type			Volante
	1.5	Load capacity	Q	t	4
	1.8	Load distance to wheel axle	x	mm	985
	1.9	Wheelbase	y	mm	1832
<b>Weights</b>	2.1	Truck weight without battery		Kg	1020
<b>Wheels and chassis</b>	3.1	Wheels			Poliuretano
	3.2	Wheels size front		mm	254x100
	3.3	Wheels size rear		mm	80x80
	3.4	Additional wheels size		mm	150x50
	3.5	Number of rear/front wheels (x = Traction wheel)			1x+2/2+2
	3.6	Front wheelbase	b10	mm	600
	3.7	Rear wheelbase	b11	mm	380
<b>Dimensions</b>	4.4	Lift height	h3	mm	115
	4.15	Height forks lowered	h13	mm	85
	4.19	Overall length	l1	mm	2315
	4.20	Length to face of forks	l2	mm	1165
	4.21	Overall width	b1	mm	1100
	4.22	Forks dimensions	s/e/l	mm	70/190/1150
	4.31	Ground clearance		mm	70
	4.32	Distanza da piano di lavoro a inizio forca	m2	mm	15
	4.34	Aisle width	ast	mm	2565
	4.35	Turning radius	wa	mm	2175
<b>Performance</b>	5.1	Travel speed with/without load		Km/h	3/6
	5.2	Lifting speed with/without load		m/s	0.11/0.33
	5.3	Lowering speed with/without load		m/s	0.5/0.2
	5.8	Maximum gradeability with/without load		%	1/3
	5.10	Service brake			elettrico
<b>Motor</b>	6.1	Traction motor S2 60 min.		Kw	2.5
	6.2	Lift motor S3		Kw	2.2
	6.3	Battery			Piombo acido
	6.4	Battery - voltage and nominal capacity		V/Ah	24V 420 Ah
	6.5	Battery weight		Kg	370
	Dim. batteria	Battery size		mm	1015/257/575
<b>Other</b>	8.1	Traction control			proporzionale
	8.4	Noise level driver place			<70