

TRS 30- 70 OB XT MINIDONKEY

CS Italia s.r.l.



Optional su richiesta info@carrellispeciali.it ✉

TRS 30- 70 OB XT MINIDONKEY

CS Italia s.r.l.

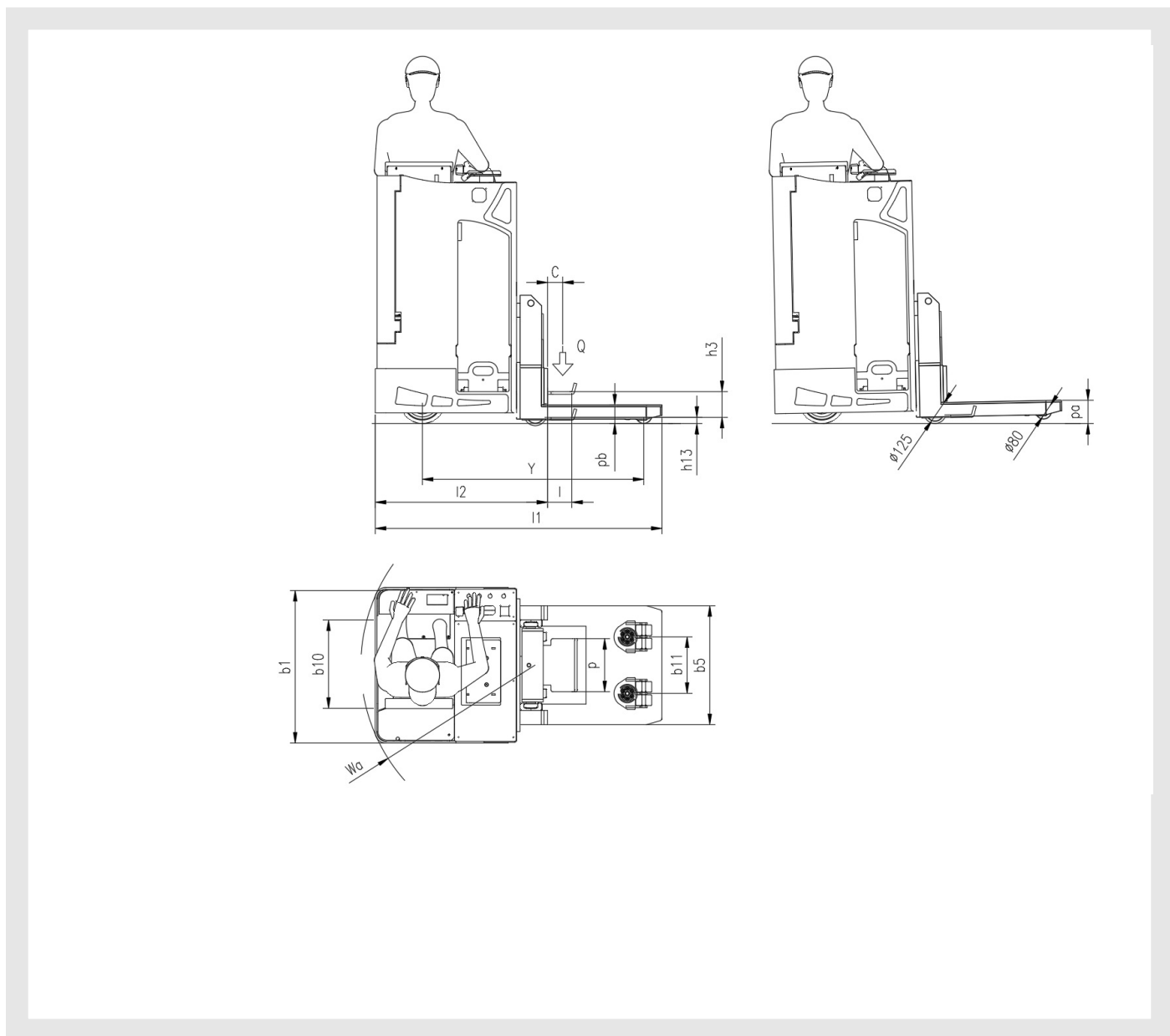

Illustrazioni e dati tecnici non sono impegnativi. Il costruttore si riserva il diritto di apportare modifiche senza preavviso.

Tipologia TRS 30- 70 OB XT MINIDONKEY

Categoria Aeroportuali

| | | | | | |
|---------------------------|---------------|--|-------|------|-----------------------------|
| General info | 1.1 | Manufacturer | | | CSI s.r.l. |
| | 1.2 | Model | | | TRS 30- 70 OB XT MINIDONKEY |
| | 1.3 | Drive | | | elettrico |
| | 1.4 | Operator type | | | a volante |
| | 1.5 | Load capacity | Q | t | 3 |
| | 1.5a | Towing capacity | Q1 | t | 7 |
| | 1.9 | Wheelbase | y | mm | 2150 |
| Weights | 2.1 | Truck weight without battery | | Kg | 800 |
| Wheels and chassis | 3.1 | Wheels | | | Poliuretano |
| | 3.2 | Wheels size front | | mm | 254x100 |
| | 3.3 | Wheels size rear | | mm | 125X40 |
| | 3.4 | Additional wheels size | | mm | 80X60 |
| | 3.5 | Number of rear/front wheels (x = Traction wheel) | | | 1x+2/2+2 |
| | 3.6 | Front wheelbase | b10 | mm | 500 |
| | 3.7 | Rear wheelbase | b11 | mm | 320 |
| Dimensions | 4.4 | Lift height | h3 | mm | 145 |
| | 4.15 | Height forks lowered | h13 | mm | 35 |
| | 4.19 | Overall length | l1 | mm | 1605 |
| | 4.20 | Length to face of forks | l2 | mm | 970 |
| | 4.21 | Overall width | b1 | mm | 880 |
| | 4.22 | Forks dimensions | s/e/l | mm | 137 |
| | 4.22a | Pallet width | p | mm | 300 |
| | 4.25 | Overall forks width size | b5 | mm | 672 |
| | 4.26 | Raised platform | pa | mm | 120 |
| | 4.27 | Lowered platform | pb | mm | 105 |
| | 4.31 | Ground clearance | | mm | 40 |
| | 4.35 | Turning radius | wa | mm | 980 |
| Performance | 5.1 | Travel speed with/without load | | Km/h | 3/6 |
| | 5.2 | Lifting speed with/without load | | m/s | 0,04/0,05 |
| | 5.3 | Lowering speed with/without load | | m/s | 0.5/0.2 |
| | 5.8 | Maximum gradeability with/without load | | % | 1/3 |
| | 5.10 | Service brake | | | elettrico |
| Motor | 6.1 | Traction motor S2 60 min. | | Kw | 2.5 |
| | 6.2 | Lift motor S3 | | Kw | 2.2 |
| | 6.3 | Battery | | | Piombo acido |
| | 6.4 | Battery - voltage and nominal capacity | | V/Ah | 24V465 |
| | 6.5 | Battery weight | | Kg | 360 |
| | Dim. batteria | Battery size | | mm | 800/280/800 |
| Other | 8.1 | Traction control | | | proporzionale |
| | 8.4 | Noise level driver place | | | <70 |